

General Requirements for Residential Electrical Installations



January 1, 2021

DREMC General Requirements for Residential Electrical Installations

In addition to the National Electrical Code, National Electrical Safety Code, and state and local building codes, DREMC has installation requirements which must be followed.

Please check with an DREMC engineer or representative before locating the meter base or if you have questions about requirements or specifications.

General Specifications

A. Overhead Residential Services

1. Where a DREMC engineering representative specifies an eyebolt for service attachment, install the eyebolt at a point lower than the weatherhead and no more than 18" horizontally from the weatherhead.
2. Where a DREMC engineering representative specifies a service mast for service attachments, install 2 1/2-inch rigid metal conduit (RMC) fastened with a minimum of 2 mast clamps bolted through the wall on all residential services.
3. In no case shall a residential point of attachment be less than 12 ft.
4. All services must comply with Codes requirements for clearance. Codes can require more than 12' of clearance at midspan in many situations. DREMC's engineering representative will assist in determining the required clearance.
5. See DR-91 for additional specification details.

B. Overhead Non-Residential Services

1. Where a DREMC engineering representative specifies an eyebolt for service attachment, install the eyebolt at a point lower than the weatherhead and no more than 18" horizontally from the weatherhead.
2. Where a DREMC engineering representative specifies a service mast for service attachments, install 2 1/2-inch rigid metal conduit (RMC) fastened with a minimum of 2 mast clamps bolted through the wall on all residential services.
3. All services must comply with Codes requirements for clearance.
4. The DREMC Service conductor must maintain a minimum 16 ft. ground clearance at midspan on all non-residential service lines. See an DREMC engineering representative to confirm that the proposed point of attachment height will achieve sufficient ground clearance. If the point of attachment does not comply with the clearance requirements, DREMC will not energize the service.
5. See DR-91 for additional specification details.

C. Underground Services

Responsibility of the Member:

Trench:

1. The Member will be responsible for the trenching and backfilling necessary for the installation of underground facilities.
2. The trench is to be 30" in depth and must be inspected by DREMC prior to backfilling.
3. The trench must be backfilled with clean, rock free dirt or bedded 6" above and below the conduit with fine (1/4" down) gravel.
4. No large rock, brick, trash, or debris will be permitted as backfill.
5. A joint-use trench with gas, water, and sewer will not be allowed. Where gas, water and sewer run parallel to a secondary conduit, a minimum of 48" horizontal separation is required. Where gas, water, and sewer cross a secondary conduit, a minimum of 12" vertical separation is required.
6. A joint-use trench with communications (telephone and cable television) must have a minimum 12" vertical separation from the secondary conduit.
7. Communications (telephone and cable television), gas, water, and sewer conduits, equipment and meters must be located a minimum of 48" horizontally from DREMC's secondary boxes.

Conduit System

1. All conduits shall be supplied by the Member.
2. The conduit used below grade shall be 3" schedule 40 PVC, grey electrical conduit for 400 amps and less service entrances.
3. The conduit located on the pole shall be 3" rigid metal conduit, the length of which will be specified on a per job basis. The elbow at the pole shall be rigid metal conduit with a minimum bend radius of 24". The conduit attached to the house, below the meter base, shall be 3" rigid metal conduit securely fastened with two straps, two feet apart. The elbow at the meter base shall be rigid metal conduit with a minimum bend radius of 24".
4. A weatherhead and grounding clamp supplied by the member, will be required at the top of the riser pole conduit.
5. The conduit located inside a pad mount transformer or underground secondary box for secondaries shall be 3" schedule 80 PVC, grey electrical conduit. The elbows at a pad mount transformer or underground secondary box for secondaries shall be schedule 80 PVC, grey electrical conduit with a minimum bend radius of 24". Size of service conduit to be specified by DREMC.

6. The conduit below grade and the elbows shall be installed by the member. The location and installation of the pole conduit must be coordinated with DREMC. The pole conduit will be installed by DREMC.
7. During construction, the conduit system is to be capped with threaded caps to prevent debris from entering the system.
8. A pull rope (1/4" polypropylene rope) must be installed in the conduit system by the member.
9. See DR-150 for specification details.

D. Manufactured and Modular Home Services

1. A **red** HUD label identifies **manufactured** or **mobile** homes. Meters may not be installed on manufactured or mobile homes. DR-19 for specification details.
2. **Modular** homes are identified by a **green** State of Tennessee label. Services for modular homes may be identical to overhead or underground residential services.
3. See DR-91 and DR-150 for specification details.

E. Temporary Services

1. Overhead - Temporary service pole must be within 100 ft. of DREMC pole. See DR-90 for specification details.
2. Underground - Temporary service pole must be located behind right corner of pad mount transformer or underground secondary box. See DR-151 for specification details.

Duck River Electric Membership Corporation

Typical Meter Pole Installation for Manufactured Home

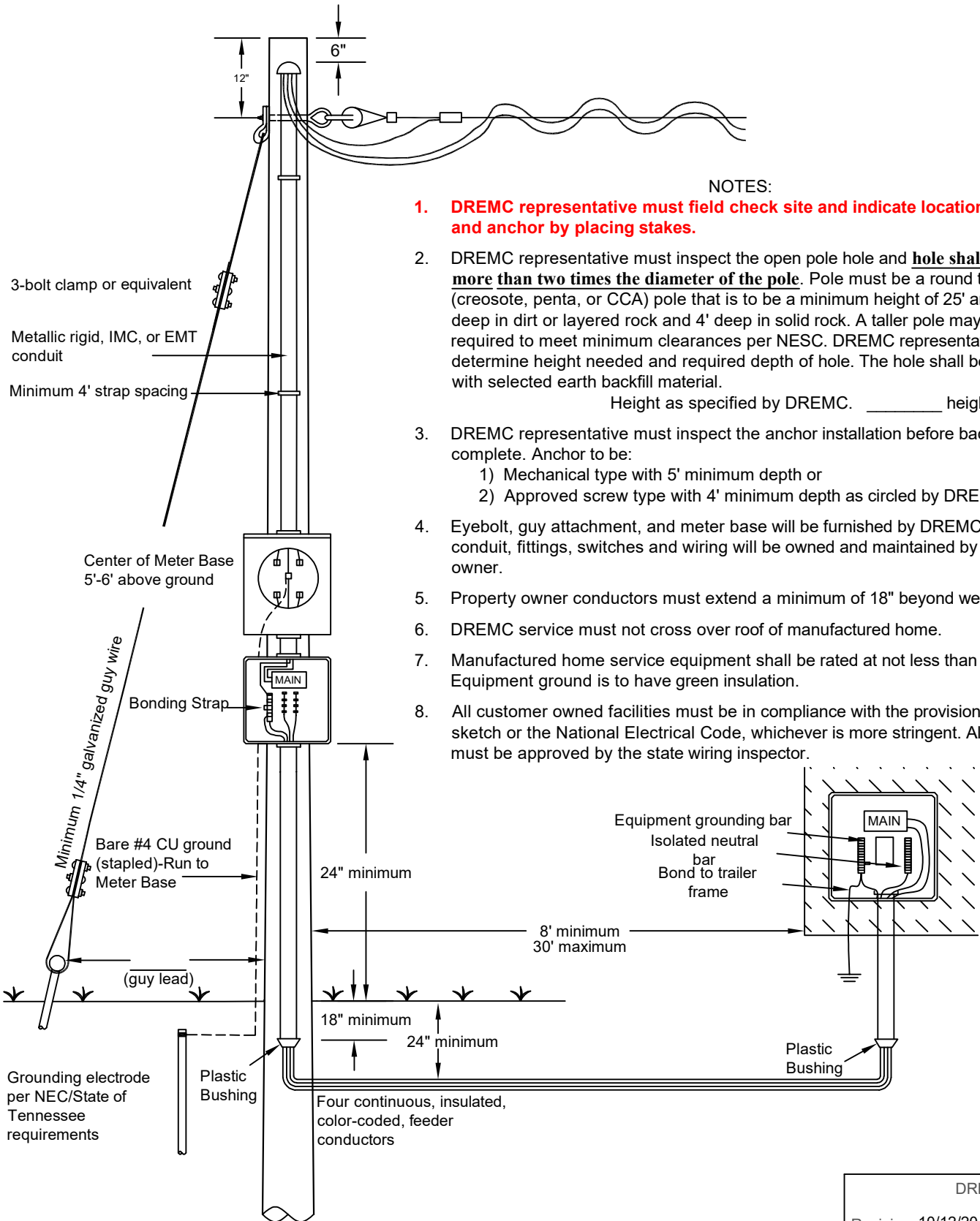

NOTES:

1. **DREMC representative must field check site and indicate location for pole and anchor by placing stakes.**
2. DREMC representative must inspect the open pole hole and **hole shall not be more than two times the diameter of the pole.** Pole must be a round treated (creosote, penta, or CCA) pole that is to be a minimum height of 25' and set 5' deep in dirt or layered rock and 4' deep in solid rock. A taller pole may be required to meet minimum clearances per NESC. DREMC representative shall determine height needed and required depth of hole. The hole shall be backfilled with selected earth backfill material.
Height as specified by DREMC. _____ height.
3. DREMC representative must inspect the anchor installation before backfill is complete. Anchor to be:
 - 1) Mechanical type with 5' minimum depth or
 - 2) Approved screw type with 4' minimum depth as circled by DREMC.
4. Eyebolt, guy attachment, and meter base will be furnished by DREMC. All conduit, fittings, switches and wiring will be owned and maintained by property owner.
5. Property owner conductors must extend a minimum of 18" beyond weatherhead.
6. DREMC service must not cross over roof of manufactured home.
7. Manufactured home service equipment shall be rated at not less than 100 amps. Equipment ground is to have green insulation.
8. All customer owned facilities must be in compliance with the provisions of this sketch or the National Electrical Code, whichever is more stringent. All wiring must be approved by the state wiring inspector.

DREMC	
Revision:	10/12/20
Issued By:	_____
Received By:	_____
Date:	_____

Duck River Electric Membership Corporation

Typical Overhead Temporary Service

NOTES:

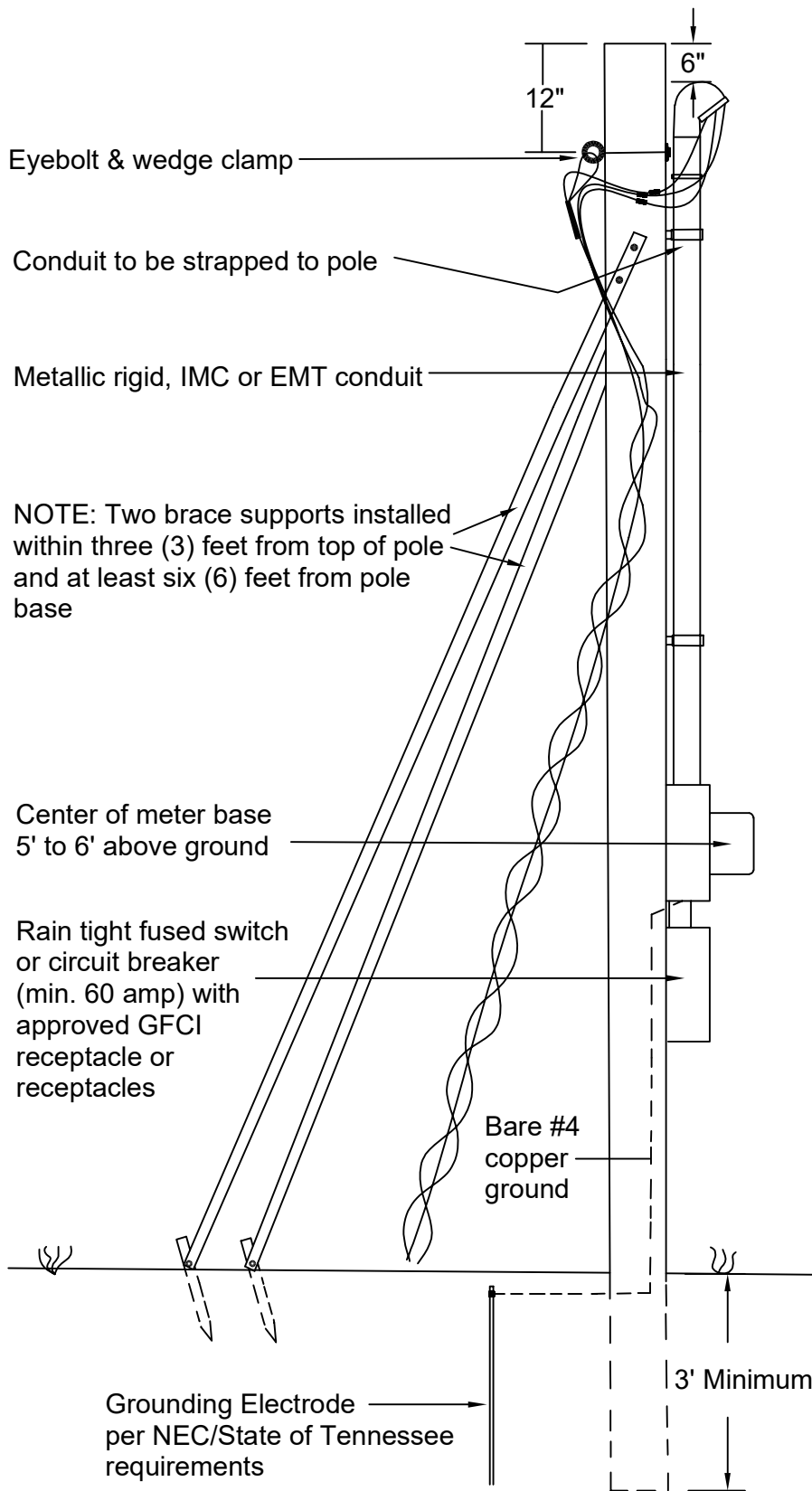

1. Temporary service pole must be spotted by DREMC.
2. All customer owned facilities must be in compliance with the provisions of this sketch or the National Electrical Code, whichever is more stringent. All wiring must be approved by the state wiring inspector.
3. It is recommended that the neutral not be cut in the meter base.
4. A) Point of service drop attachment will be sufficient height to provide a minimum clearance of 12' at midspan.
 B) If vehicles greater than 8' are subject to accessibility a minimum clearance of 16' required at midspan.
5. DREMC will provide a length of triplex conductor, along with an eyebolt, connectors, and wedge clamp for attachment to temporary pole. DREMC will not make up connections at top of temporary pole.
6. DREMC will require temporary service pole to be re-inspected by the Deputy Electrical Inspector if the temporary has been in the field for (1) year.
7. The maximum length of the temporary service is 100'.

DREMC	
Revision:	10/12/20
Issued By:	_____
Received By:	_____
Date:	_____

Duck River Electric Membership Corporation

Guidelines for Overhead Residential and Non-Residential Service 400 amps or less

NOTE: MUST MEET WITH A DREMC REPRESENTATIVE PRIOR TO ANY INSTALLATION OF EQUIPMENT.

- 1-1. Weatherhead must be above point of service drop attachment.
- 1-2. An eyebolt and related hardware will be furnished by DREMC for installation by the member. The eyebolt must pass through a plate spanning two or more wall studs. The eyebolt must be below and within 18" of weatherhead. Point of service drop attachment will be sufficient height to provide minimum clearances as specified by the National Electrical Safety Code as determined by DREMC field engineer.
- 1-3. Service entrance conductors will extend 18" out of weatherhead.
- 1-4. Rigid conduit, IMC, or EMT, with rain tight couplings and connectors may be used as service entrance conductor raceway. Service entrance raceways will be fastened through the exterior wall with a minimum of 2 conduit straps; the lower being within 3' of top of meter base. For 200-225 amp service, 2" conduit is required. For 400 amp service, 3" conduit is required.
- 1-5. A meter base and hub, of proper size and type, will be furnished by DREMC for installation by the member. Meter base will be located between 5' and 6' above final grade, on end of house closest to service pole, at a point marked by DREMC engineer. Meter base will not be located on or under porches, decks, or carports. If service entrance panel is not located in immediate vicinity of meter, a weatherproof disconnect may be required, refer to National Electrical Code.
- 1-6. A ground wire of no. 4 copper or larger shall be run unspliced from a lug in the meter base to a grounding electrode (per NEC/State of Tennessee requirements).
- 1-7. Where a mast riser is used, weatherhead will be a minimum of 36" above roof. If weatherhead is more than 42" above roof, a guy wire with eyebolt through rafter is required.
- 1-8. Service clevis assembly will be furnished and installed by DREMC.
- 1-9. Service mast will be a minimum of 2-1/2" metallic rigid conduit secured with a minimum of 2 mast clamps fastened through the wall with 1/2" clambolts: the lower being within 3' of meter base. For 200/225 amp service, 2-1/2" conduit is required. For 400 amp service, 3" conduit is required.

NOTE: All customer owned facilities must be in compliance with the provisions of this sketch or the National Electrical Code, whichever is more stringent. All wiring must be approved by the state wiring inspector.

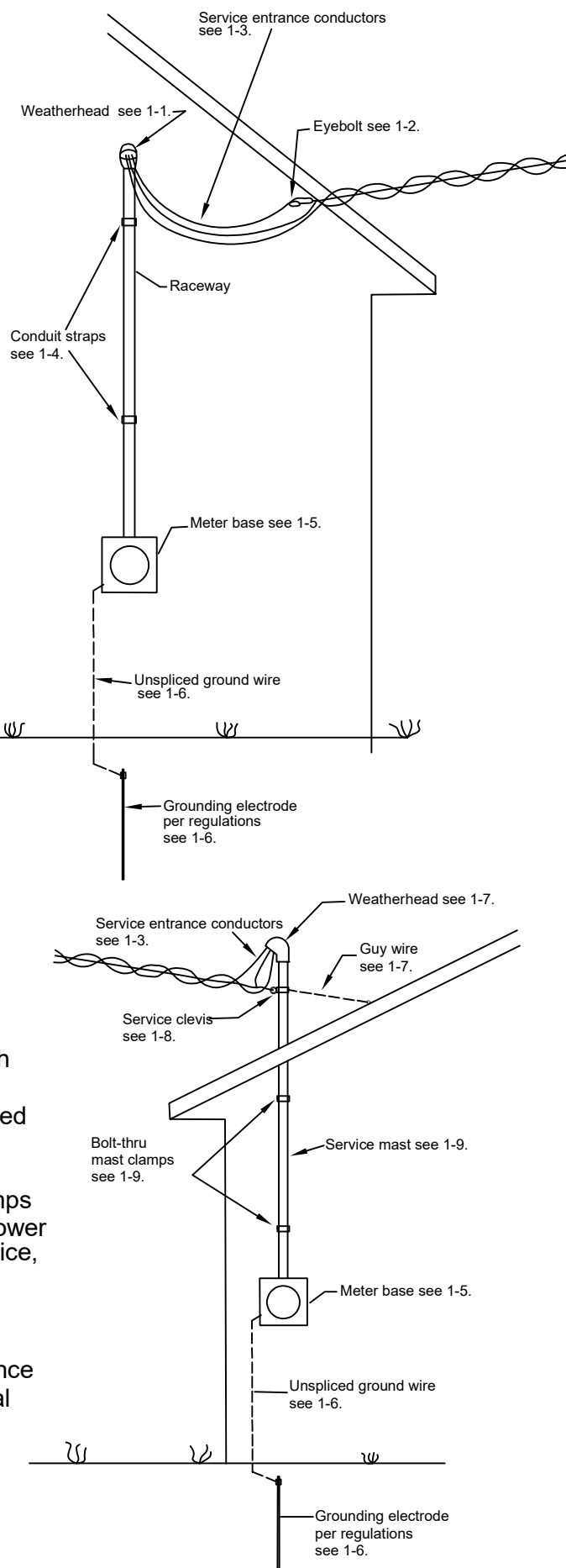

Duck River Electric Membership Corporation

Requirements for Underground Residential Service

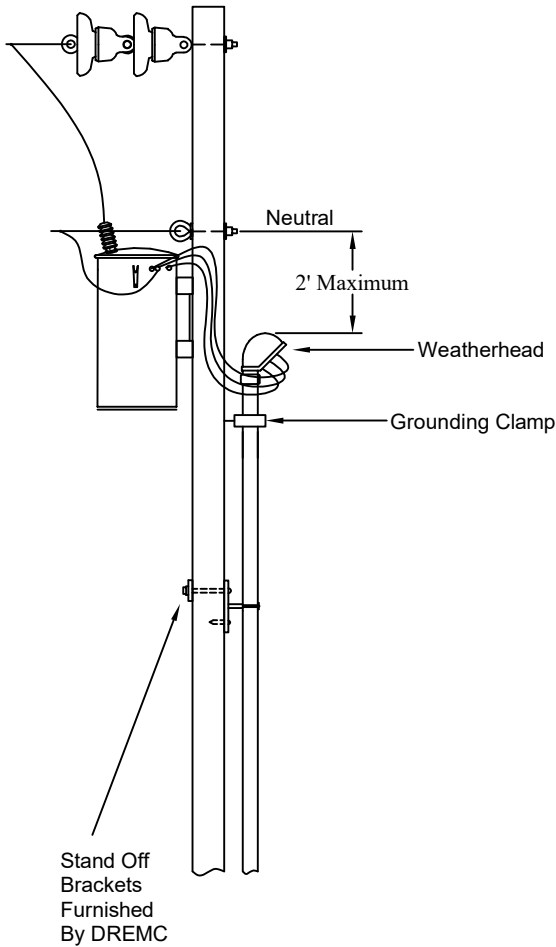

Member to Furnish & Install

- Metallic Rigid Conduit & Straps on Exterior Wall
- Schedule 40 Electrical PVC between elbows
- Minimum 24" Radius Metallic Rigid Sweeps
- Install Pull Rope in Conduit (1/4" Polypropylene)

Member to Furnish & Leave by Pole

- Metallic Rigid Conduit Per Specified Size & Length
- Weatherhead
- Conduit Grounding Clamp

Metallic Rigid Conduit Length

- Conduit Length _____
(DREMC Engineer to specify length)

Conduit Size

- 225 Amp or less - 3"
- 400 Amp - 3"
- 600 Amp - 4" (Unless specified differently by DREMC Engineer)

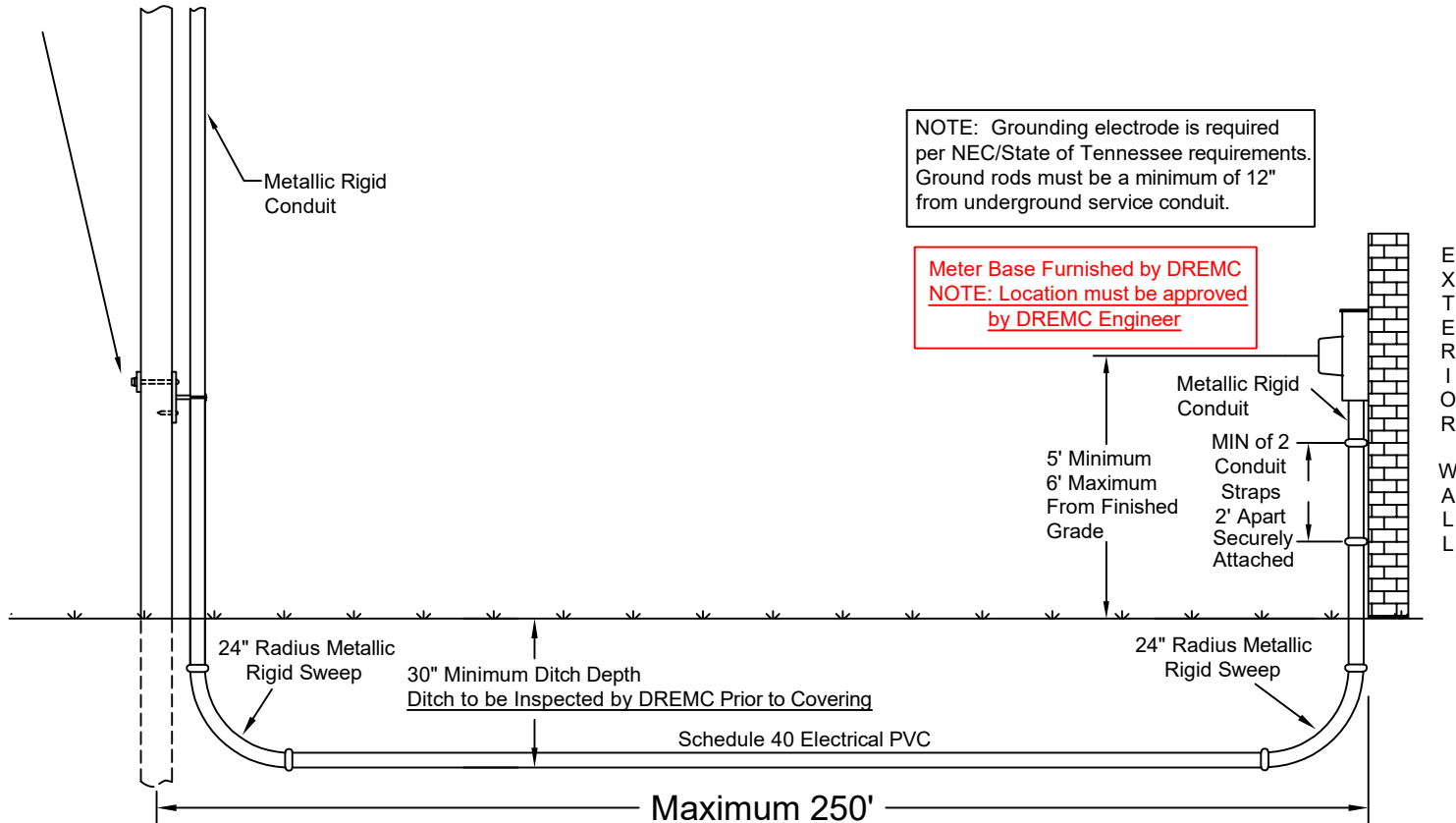

NOTE: Grounding electrode is required per NEC/State of Tennessee requirements. Ground rods must be a minimum of 12" from underground service conduit.

Meter Base Furnished by DREMC
NOTE: Location must be approved by DREMC Engineer

EXTERIOR WALL

Duck River Electric Membership Corporation

Temporary Underground Service

NOTES:

1. DREMC Engineer must spot location for temporary service.
2. Call Tennessee One Call (1-800-351-1111) before you dig. Member must hand dig within 5' of marked conductors.
3. Securely fasten service equipment and meter base to a 4x4 post set in the ground a minimum depth of 3'.
4. Service entrance raceway of 1 1/4" SCH 80 conduit will extend from meter base to 24" below grade. Conduit to enter meter base below live parts.
5. Temporary service post shall be placed behind the transformer, on the right hand side, no less than 6' away unless permitted by a DREMC authorized employee.
6. Stop trench 1' from DREMC pad and leave excess wire coiled in open part of trench. Cover all but last foot of trench following inspection by state inspector. DREMC to dig and install wire for remaining distance.
7. Service entrance conductors shall be provided by the member. Conductor shall also be rated for direct burial and in compliance with the National Electrical Code. Conductors shall be long enough to reach DREMC low side terminals without splicing. Connections at transformer cabinet will be made by DREMC.
8. Center of meter base will be located approximately 5'-6" above grade.
9. All weatherproof, UL listed, temporary service panel will be located on the same structure as the meter base. In no case will the panel be less than 2' above grade.
10. A minimum No. 4 copper wire shall be run unspliced from the meter base to a 8' driven ground rod. Bond to the ground wire with a clamp suitable for direct soil burial below grade.
11. Temporary service must be in compliance with the provisions of this sketch or the National Electrical Code, Whichever proves more stringent. All wiring must be approved by the state inspector.

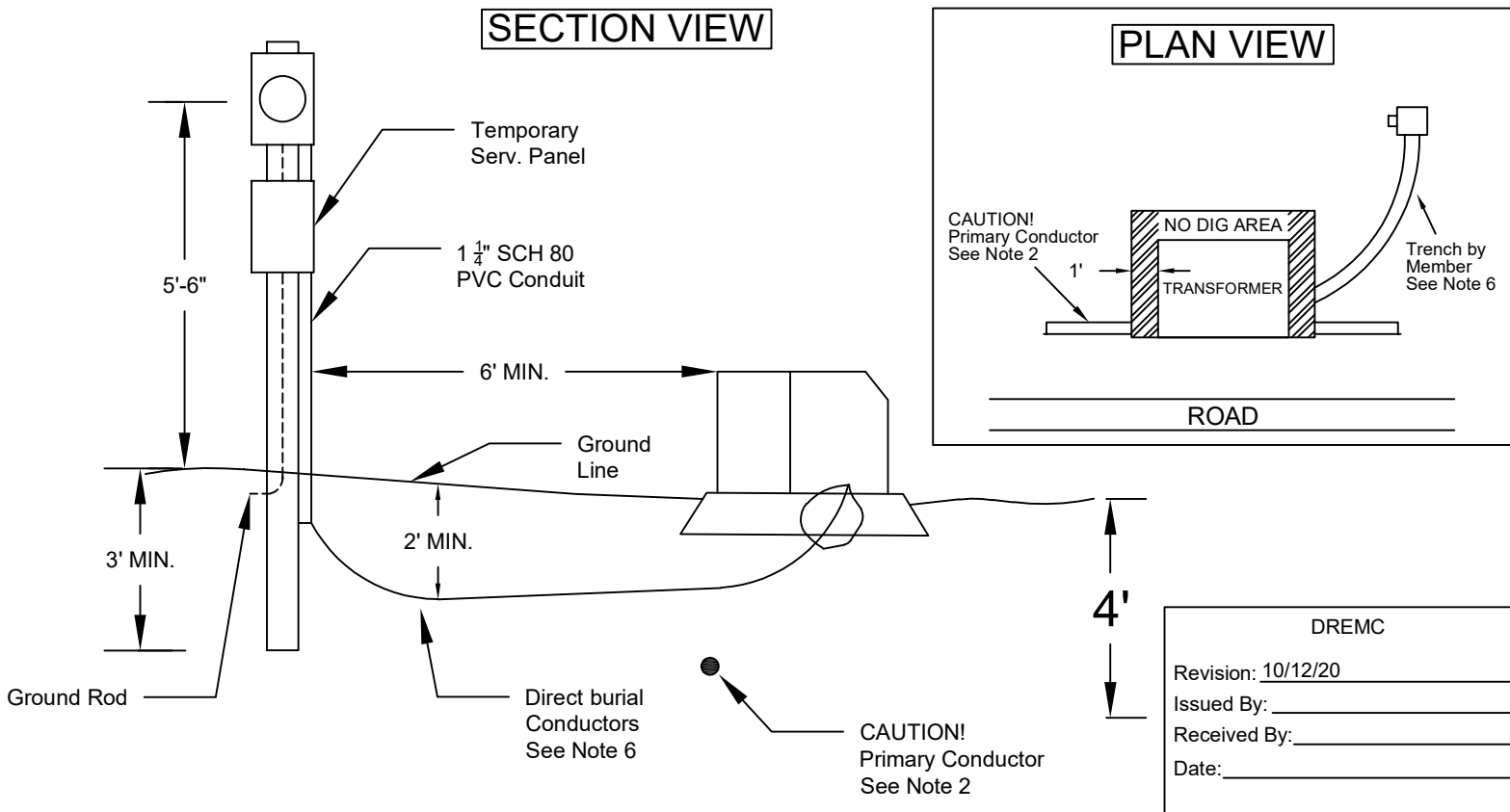

DUCK RIVER ELECTRIC MEMBERSHIP CORPORATION

400 or Less Amp Single Phase Meter Center

TYPICAL 400 AMP OR LESS SINGLE PHASE METER CENTER

Note: Must meet with DREMC prior to digging and installation of equipment

1. DREMC RESPONSIBILITIES:

- a.) Meterbases (400A or less). Location to be determined by DREMC Representative.
- b.) Conduit brackets at the pole and will install them per specifications.

2. MEMBER RESPONSIBILITIES:

- a.) Member shall furnish and install first stick of conduit at the pole and provide weatherhead, conduit grounding clamps, and additional conduit as determined by DREMC Field Representative. (Conduit length at pole = _____)
- b.) Conduit size shall be 3" rigid metal conduit with a EL sweep with minimum 24" radius.
- c.) Continuous raceway from transformer shall be scheduled 40 electrical PVC conduit and shall have a minimum depth of 30" at final grade. Maximum length of 250'.
- d.) Support members shall be constructed of 6x6 treated posts or 2" metal rigid conduit and set 3 feet below final grade. If rigid metal conduit, caps shall require on pole.
- e.) Cross member supports shall be constructed of treated wood or metal unistrut.
- f.) Center of the meter shall be 5'6" from final grade.

3. ADDITIONAL NOTES:

- a.) All wiring must meet NEC and local requirements and approved by state electrical inspector.
- b.) Grounding electrode as required per NEC/State of Tennessee requirements. Ground rods must be a minimum of 12" from underground service conduit.

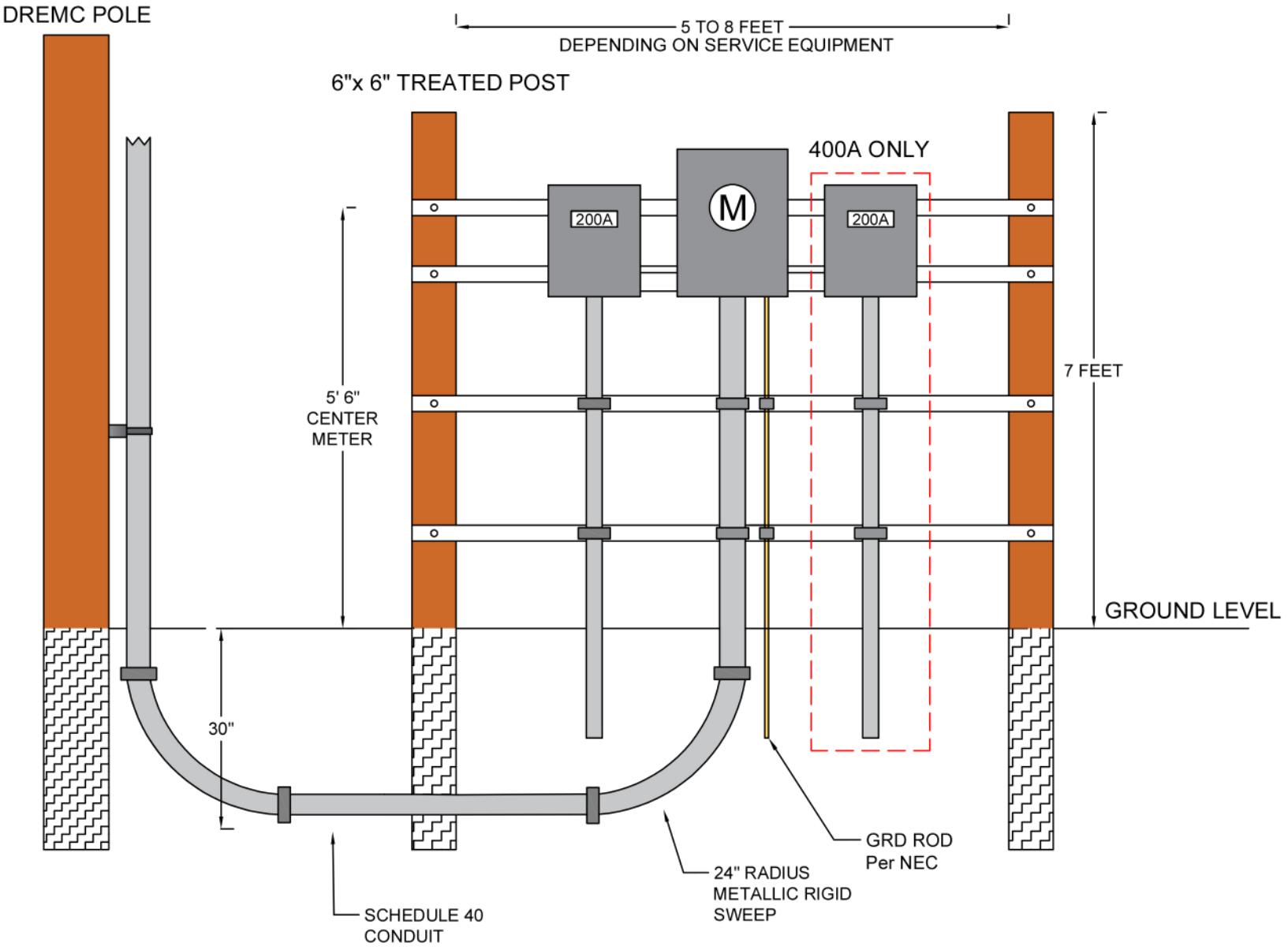

DREMC	
Revision:	10/12/20
Issued By:	_____
Received By:	_____
Date:	_____